

NOT SHOWN: 3M LOCKING CABLE AND 2M
UNTERMINATED TRIGGER CABLE

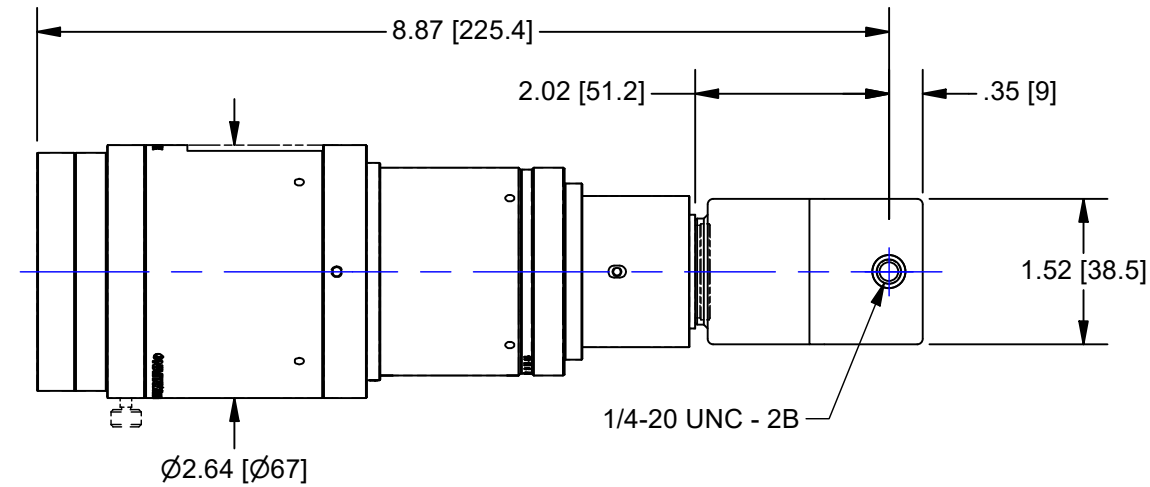

OUTLINE

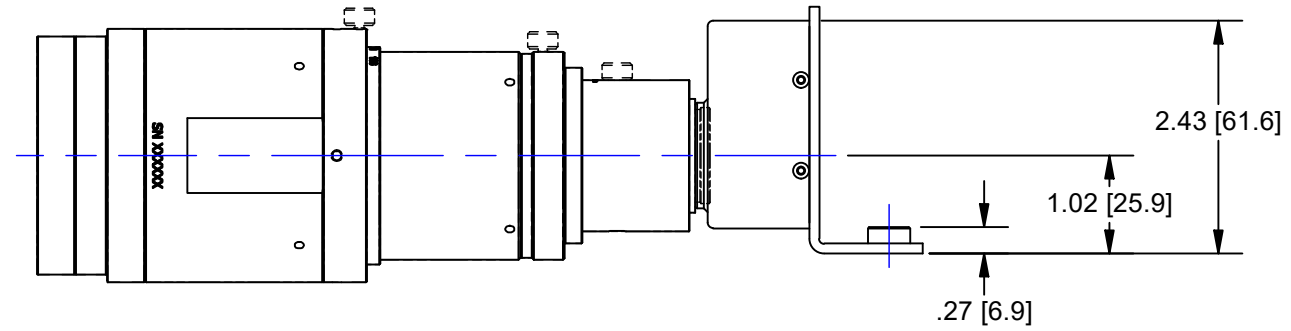
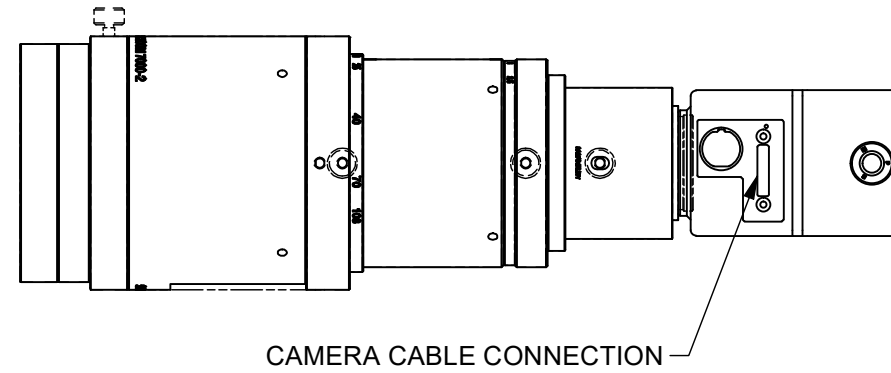
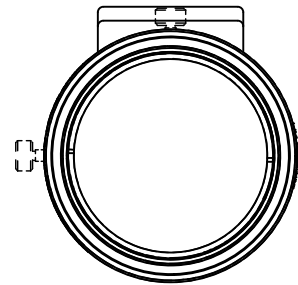

PL-D753CU WITH ZOOM7000-2

UNLESS OTHERWISE SPECIFIED DIMENSIONS ARE IN INCHES [MM] AND INCLUDE CHEMICALLY APPLIED OR PLATED FINISHES		PROPRIETARY AND CONFIDENTIAL THE INFORMATION CONTAINED IN THIS DRAWING IS THE SOLE PROPERTY OF NAVITAR. ANY REPRODUCTION IN PART OR AS A WHOLE WITHOUT THE WRITTEN PERMISSION OF NAVITAR IS PROHIBITED.		SIZE B	
SCALE:	1 / 2	0.0 inch 1.0 0.0 mm 25.0			
WEIGHT:	1.96 lbmass	DO NOT SCALE DRAWING		PART NUMBER	
DR BY:	C.CRAGON			1-101674	
CH BY:	DEROSA			REV	
PROJECT #:	E5327			A	
DATE DR:	10/9/2024				